

- LV-PECL Output Crystal Oscillator -

TYPE : CP50V / CP504****

RoHS

- LV-PECL output SPXO (25MHz to 350MHz)
- Excellent performance / Low jitter and high stability vs temperature
- Excellent reliability / Metal lid and ceramic seam welded package
- RoHS compliant

Supply Voltage	+2.5Vdd or +3.3Vdd
Output Level	LV-PECL
Dimension	5.0*3.2*1.4mm

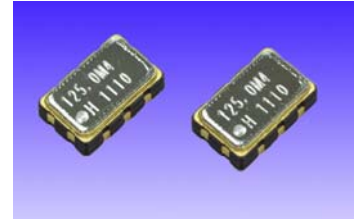

- Electrical Specifications -

* +3.3Vdd = < CP504* * > +2.5Vdd = < CP50V* * >

Item	Condition	MIN	TYP	MAX	UNIT
Frequency Range (Fo)		25	-	350	MHz
Supply Voltage	Vdd=+3.3V	+3.135	-	+3.465	V
	Vdd=+2.5V	+2.375	-	+2.625	
Total Frequency Accuracy (Including accuracy, supply voltage change, 1st year aging)	(G) option	-20	-	+20	PPM
	(A) option	-25	-	+25	
	(B) option	-50	-	+50	
	(C) option	-100	-	+100	
Operating temperature	(S) option	0	-	+70	deg.c
	(A) option	-20	-	+70	
	(B) option	-40	-	+85	
	(C) option	-10	-	+70	
Storage temperature		-50	-	+125	
Output Level	Vdd = 3.3V / VOH	2.275	-	-	V
	Vdd = 3.3V / VOL	-	-	1.680	
	Vdd = 2.5V / VOH	1.475	-	-	
	Vdd = 2.5V / VOL	-	-	1.095	
Rise Time	20% → 80%	-	0.3	0.7	ns
Fall Time	80% → 20%	-	0.3	0.7	
Duty	25MHz to 249.9MHz	45	-	55	%
	250MHz to 350MHz	40	-	60	%
Offset Level	Vdd = 3.3V	1.3 (Vdd-2.0)			V
	Vdd = 2.5V	0.5 (Vdd-2.0)			
Current Consumption	250MHz / Vdd = +3.3V	-	64	88	mA
	250MHz / Vdd = +2.5V	-	53	88	
Load	Vdd - 2.0V	50			Ohm
RMS jitter *1	Offset : 12kHz to 20MHz	-	0.2 -0.5	-	ps
Start Up Time		-	-	10	mA
E/D function	#1pin = Hi or Open : Output Enable / Low : Output Disable				

1*) Measured with E5052B signal source analyzer (Agilent technology)
(Typical RMS Jitter value is depending on Output Frequency).

< Dimension and recommended land pattern >

(Unit in mm)

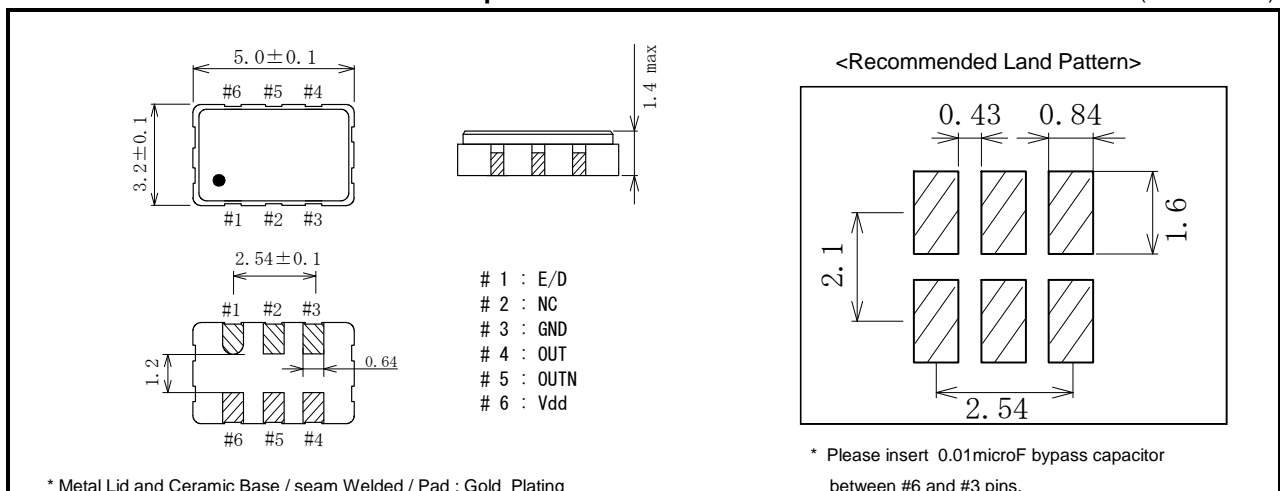

* Metal Lid and Ceramic Base / seam Welded / Pad : Gold Plating

● Output Wave Form Diagram (Single output)

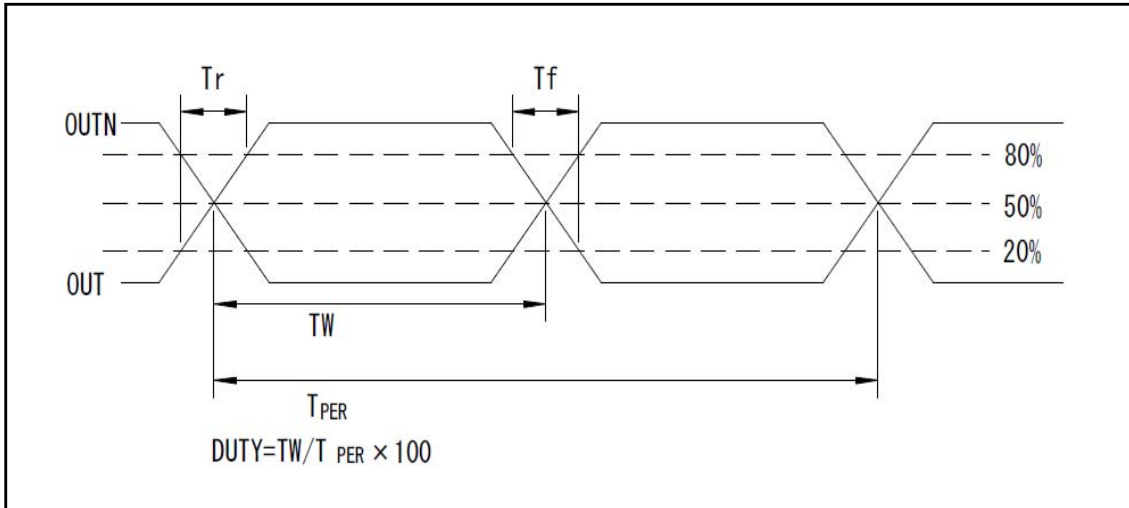

● Test circuits

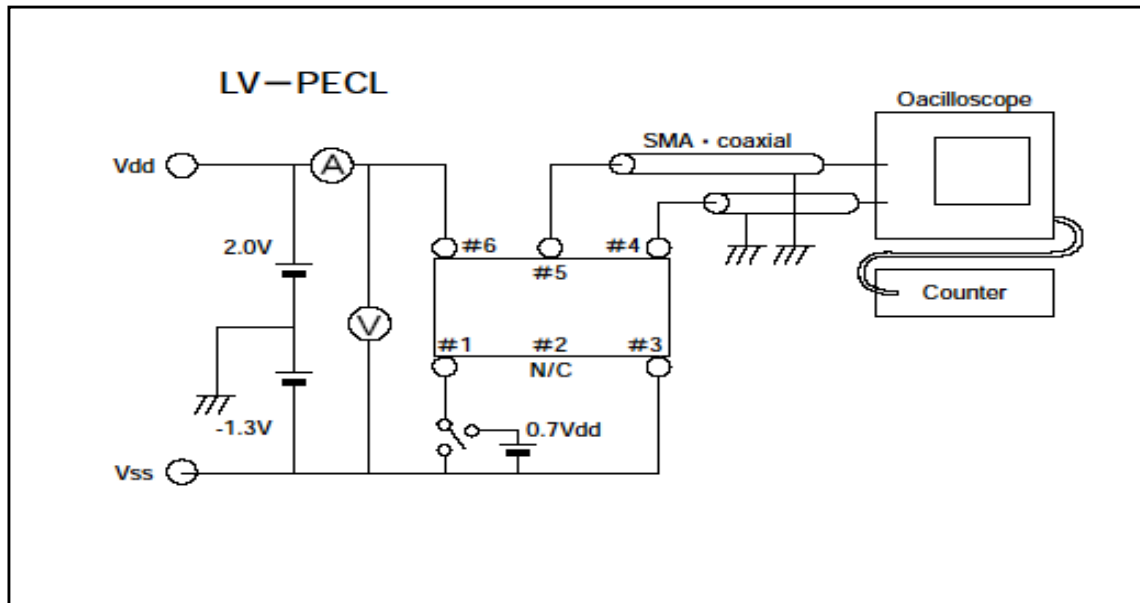

● Reflow profile

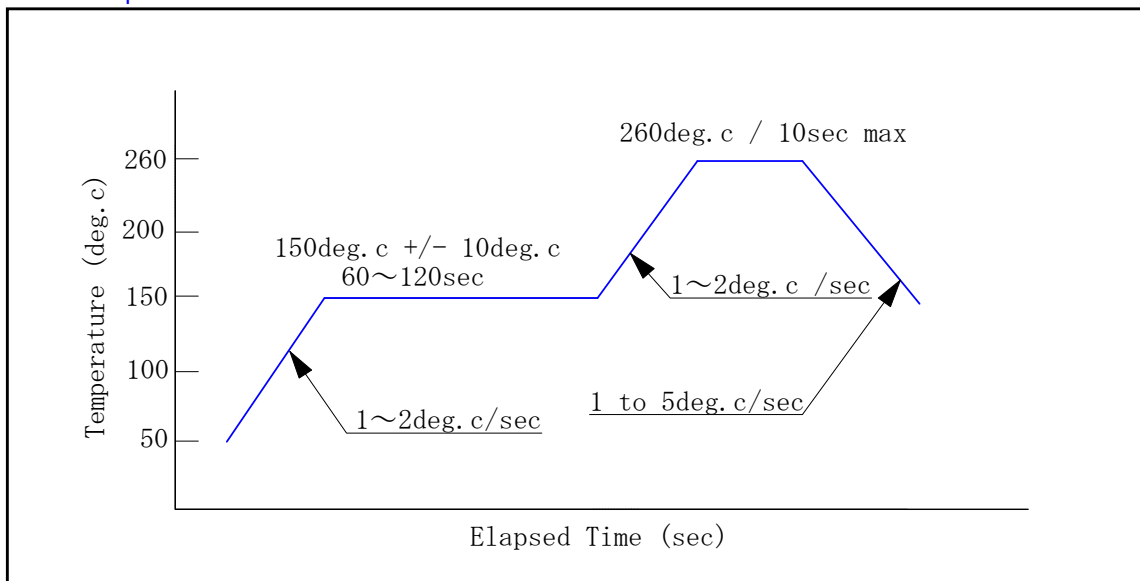

- * The reflow process can be allowed until 2 times.
- * In case of manual soldering ; using soldering iron at +360deg.c +/-20deg.c , within 3sec (per each 1pad)
- * This product includes CMOS device, then please handle it with protected process against ESD.

● How to define Model Number

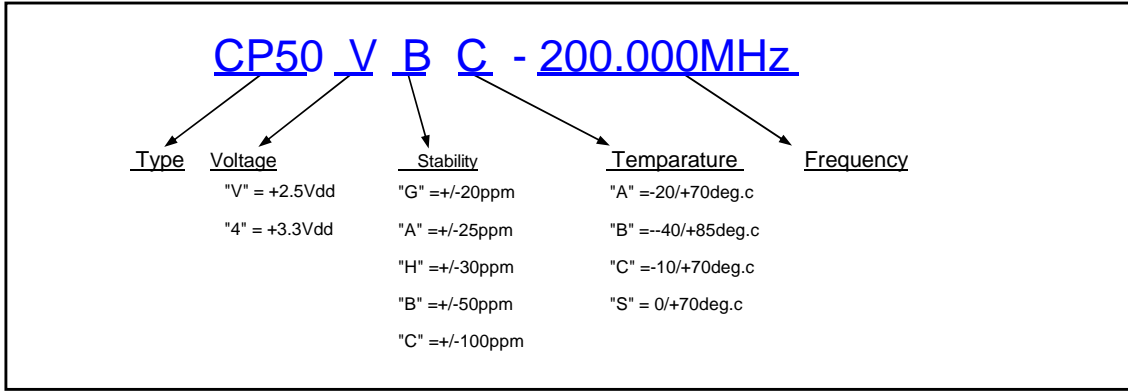

● Taping & Reel dimension

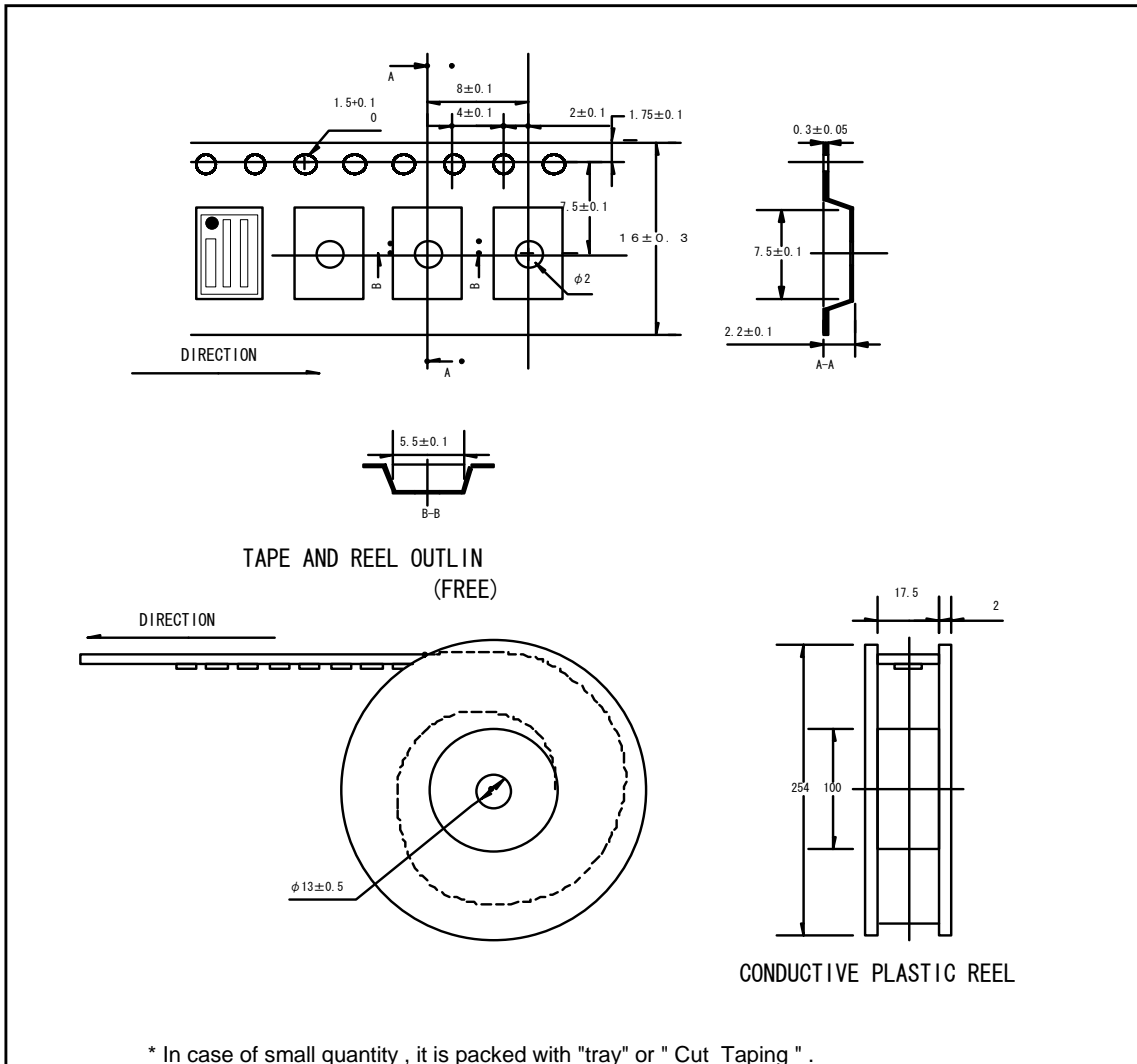

2013.05.02 Rev.C1

TamaDevice
Solution & Development

(URL) <http://www.tamadevice.co.jp>

(E-MAIL) info@tamadevice.co.jp

(TEL) +81-44-945-8028

(FAX) +81-44-945-8486

Copyright© Tamadevice.Co.,Ltd